

IPM for Flies and Mosquitoes in Schools

INTRODUCTION

Many species of flies can be problems in schools. Each kind of fly has a distinct breeding site inside or outside the school building. To manage pest flies, you must know which fly is causing the problem and where it is breeding. Common pest flies encountered in schools can be identified by characteristics shown in Table 5.

Garbage- and Manure-Breeding Flies

IDENTIFICATION AND BIOLOGY

House flies, dump flies, blue and green bottle flies, and others that breed in food wastes (garbage) and/or animal feces generally are referred to as “filth flies.”

Sometimes flies are confused with wasps; however, flies have two wings, while wasps and all other winged insects have four wings arranged in two pairs. Wasps, unlike flies, fold their wings alongside their bodies when at rest. Most pest wasps are colorfully marked with yellow, red, black, and white, and have narrowly constricted waists. Generally, wasps are less likely to come

indoors, are aggressive in their flight around foods, particularly sweets, and are larger than filth flies. Filth flies are not aggressive and do not bite. The cluster fly, which is also larger than the filth flies, can be identified by its stout body with crinkled yellow hairs.

Filth flies pass through four distinct stages in their life cycle: egg, larva (maggot), pupa, and adult. Adult female filth flies look for moist places with the right smell to lay their eggs. This can be in food waste in a garbage can or dumpster, in dog or cat feces, in dead animals, in kitchen drains, in grass clippings allowed to rot in a pile, and even in moist soil that is mixed with garbage. The larva hatches from the egg and grows until it is ready to form a puparium (a kind of cocoon), from which an adult fly will emerge. Once the adult fly emerges, it doesn't grow any larger; small flies do not grow into larger flies.

DAMAGE

Flies that invade cafeterias and kitchens are not just a nuisance. They also carry bacteria and other microbes that can contaminate food, utensils, and surfaces.

TABLE 5.

Common Flies Found In and Around Schools in Pennsylvania		
Species	Description	Sources of Infestation
House fly <i>Musca domestica</i>	$\frac{1}{4}$ – $\frac{5}{16}$ inch long; gray; 4 stripes on thorax	garbage, human and animal feces
Blow flies Green bottle fly <i>Phaenicia sericata</i>	$\frac{1}{4}$ – $\frac{5}{16}$ inch long; shiny green to bronze	garbage containing mixtures of animal and vegetable matter; dead animals; fresh meat; enters buildings less frequently than house flies
Blue bottle fly <i>Cynomyopsis cadaverina</i> , <i>Calliphora</i> spp.	$\frac{1}{4}$ – $\frac{9}{16}$ inch long; thorax dull; abdomen metallic blue	exposed meat, feces, overripe fruit, and other decaying vegetable matter; enters buildings in cool season
Cluster fly <i>Pollenia rudis</i>	larger than house fly, $\frac{3}{8}$ inch long; dark gray with distinctive yellow hairs; adults sluggish	larvae parasitic on earthworms; adults enter houses in fall
Fruit fly <i>Drosophila</i> spp.	$\frac{1}{8}$ inch long; yellow-brown	fermenting fruit and vegetables, other moist organic matter
Phorid fly (Humpbacked Fly) <i>Megaselia scalaris</i>	$\frac{1}{16}$ – $\frac{1}{4}$ inch long; more hump-backed in appearance than fruit flies	decomposing organic matter, including vegetables, fruit, flesh, and feces
Moth fly (Drain Fly) <i>Psychoda</i> spp.	$\frac{1}{16}$ – $\frac{1}{4}$ inch long; dark or grayish with wings densely covered with hairs	eggs, larvae, and pupa often found in slime or muck in drains, sewage disposal beds, moist compost, and garbage containers; adults found near same areas

Most of the information for this chapter was modified from:

IPM for Schools: A How-to Manual. United States Environmental Protection Agency. EPA 909-B-97-001. March 1997.

Information on moth flies was adapted from Lyon, W. F. *Drain Flies*. The Ohio State University Extension Fact Sheet HYG-2071-97, and Jacobs, S. B. *Moth flies in the home*. The Pennsylvania State University. Entomology-NP-6. 1998.

DETECTION AND MONITORING

It is important to correctly identify the problem flies and pinpoint their breeding sites. Some of the characteristics listed in Table 5 can help you with identification. Specimens also can be taken to a Penn State Cooperative Extension county agent, who should be able to assist in identification.

To collect specimens inside, use sticky flypaper or gather dead specimens from windowsills and light fixtures. Outside, trapping is one of the easiest methods of catching flies for identification (see page 53 for guidelines on trap construction, placement, and baits). If adult flies consistently avoid baited traps, the pest fly may not be a filth fly.

MANAGEMENT OPTIONS

To manage flies, you must find and reduce breeding sites, install and maintain screens to keep flies out of buildings, kill those flies that do get inside with a fly swatter or flypaper, and reduce or eliminate the odors that attract flies.

In a school with a frequent waste removal program, it is very possible that few flies are breeding on the school property. It is more likely that odors from dumpsters, garbage cans, kitchens, and cafeterias are attracting flies to the school from the surrounding neighborhood. House flies and blow flies, the species that most commonly invade buildings, usually develop outside and follow odors into the building. They can also be pests when students or staff are eating outside. In schools where waste removal is infrequent, fly populations can be breeding at the waste collection site.

Habitat Modification

Modifying habitat is one of the most important aspects of fly management. It is impossible to manage filth flies without controlling wastes and odors.

Food Waste

- All food waste from the kitchen, cafeteria, and other areas should be separated from other garbage, drained so it will be as dry as possible, and then stored in sealed plastic bags before discarding.
- Place containers with small amounts of food waste, such as milk or yogurt cartons, into sealed plastic bags before disposal. This will reduce access by flies.
- Promptly fix drains or electric garbage disposal units that leak, or drains that allow food waste to accumulate under sinks or floors. Leaky drains can attract many species of flies. Remove any food waste that has accumulated under sinks or floors or in crawl spaces or basements at the site of the broken drain, and then clean the area thoroughly.

Other Garbage

- In food preparation areas, rinse all cans, bottles, and plastic containers before recycling or discarding.

Exterior Garbage Cans and Dumpsters

- Inform students, teachers, and staff about the importance of placing garbage inside the proper containers. Garbage should not be left lying on the ground.
- To avoid attracting flies into the building, place dumpsters and recycling containers upwind from the outside doors of the school, particularly doors to the kitchen or cafeteria. When dumpsters are downwind, flies are attracted to the waste odors and then find the odor trails that the breeze blows down from the doorways. Following these odor trails, they find their way into the building.
- Wastes should be collected and moved off-site at least once a week. Since flies breed faster in warm weather, garbage collection twice a week may significantly reduce fly problems.
- Make sure garbage can and dumpster lids seal tightly when closed and remain closed when not in use. Do not leave lids open at night; garbage can attract other pests, such as rodents. Repair or replace garbage cans that have holes or lids that do not close tightly.
- Regularly clean garbage cans and dumpsters to prevent the buildup of food waste. Use a high-pressure stream of water or a brush and soapy water, if necessary. A solution of borax and water will eliminate odors. Do not allow soured milk to collect in trash receptacles; it is a powerful attractant to flies. If possible, dumpsters should be fitted with drains so they can be hosed or scrubbed out as needed. Another option is to require the refuse company to clean the dumpster or replace it with a clean one more frequently. Some pest management companies will power-wash dumpster and dumpster areas as part of their service.
- Flies can develop in soil soaked with water used to clean garbage cans and dumpsters. Check these areas regularly. If you see maggots, scrape them up along with the soil and dispose of everything in a tightly sealed plastic bag.
- Inspect dumpsters and other outdoor trash receptacles daily, and remove any wastes lying on the ground.
- Garbage cans on the school grounds should have removable domed tops with self-closing, spring-loaded swinging doors. Cans should be lined with plastic bags that can be tightly sealed and removed daily.
- If children do not have access to dumpsters, baits inside and residual insecticides on the outsides of dumpsters work well.

Animal Feces

Remove droppings promptly and put them into plastic bags that are sealed before disposal. Dog feces that dry quickly may attract adult flies with their odor, but are unlikely to host many maggots. Droppings that remain damp because of humidity or rain can breed a number of maggots.

Odor

Flies can detect odors across long distances. Smells of souring milk from hundreds of containers thrown in dumpsters can attract thousands of flies from the surrounding neighborhood. Storing garbage in sealed plastic bags and having cans and dumpsters cleaned and emptied frequently to eliminate odors is very important. Removing pet feces also helps to reduce odors that attract flies.

Flies attracted to open kitchen or cafeteria doors, or to dumpsters or garbage, will rest on nearby walls, eaves, and rafters. While resting, they leave fly specks, which have a strong fly-attracting odor. These brown- to cream-colored specks should be washed off with an odor-eliminating cleaner (a mild solution of borax and water can be particularly effective); otherwise, they will continue to attract flies.

Physical Controls

Screens

Install screens over windows, doors, and vent holes to prevent flies from entering buildings. Weather-stripping or silicone caulk can be used to ensure a tight fit. Torn screens can be repaired with clear silicone caulk. Screen doors should be fitted with springs or automatic closing devices that close the screen door firmly after it is opened. External doors that cannot be screened should be fitted with automatic closing devices, and/or vertical strips of overlapping plastic that allow human access but prevent fly entry. "Air curtains" that force air across openings are another alternative to screen doors.

Fly Swatters

In many instances, the old-fashioned fly swatter is the safest and quickest way to kill flies that have found their way into a room. Aim the fly swatter about 1½ inches behind the fly, rather than directly at it, because research has shown that when a house fly takes off from a horizontal surface, it jumps upward and backward. Stiff plastic swatters seem to work better than wire-mesh ones. The fly's unblurred range of vision is about 1½ feet, and the swatter can be moved to this distance before striking.

Flypaper

Sticky flypaper is effective at catching flies because it takes advantage of their natural habit of moving up to the ceiling to rest. It will take several days for a new strip of flypaper to start catching flies. Use a number of strips at a time and replace them when they are covered with flies or when they begin to dry out. Flypaper can be very useful in areas where there are too many flies to kill with a fly swatter, and where aesthetic appeal is not of primary importance. Flypaper is also a useful monitoring tool. Do not place flypaper or sticky strips above or near food preparation areas.

Fly Traps

Fly traps can be used to reduce adult fly populations, capture specimens for identification, and monitor the effectiveness of management programs. Fly traps are not toxic and are more selective than using insecticide. Traps need to be serviced regularly, placed appropriately, and repaired or replaced when damaged.

Trapping Flies Indoors

Electrocuting light traps often are used indoors. The Food and Drug Administration states that they should be "installed no closer than 5 feet from exposed items." Light traps will not work well in a room with many and/or large windows, because the bright light coming in the windows is a much more powerful attractant than the comparatively weak light coming from the trap. Light traps do work well at night.

Some companies are now producing fly traps that lure the flies to a hidden glue board with a near-UV black light specially designed to attract flying insects. These were developed for cafeterias, fast food operations, and school lunchrooms.

Contrary to the advice provided in some promotional literature for ultraviolet light or electrocutor traps, these traps should not be used outdoors. They are relatively nonselective in the insects they attract and will kill many more beneficial and innocuous insects than pests.

The following are key points to remember when using light traps for indoor flies:

- Use the number of traps recommended by the manufacturer, or, as a general rule, one trap for every 30 feet of wall.
- Ideally, traps should be mounted 3 feet from the floor on the perimeter walls of the room, because hungry flies circle the perimeter of a room close to the floor when looking for food. They should also be placed 5 feet away from any open food and 25 feet from any doors or windows. Traps work best in rooms without windows.

A pest management professional can help with trap placement recommendations.

- Empty and clean the traps weekly to prevent dead flies from becoming an attractive food source for other insects.
- Replace lamps at least once a year.
- The more expensive black light “blue” bulbs do not attract more flies than regular black light bulbs.
- The lamp should be directed toward the interior of the building. Do not place traps where flies that are outside can see the light bulb. This may attract more flies.
- Place traps near odor sources such as cooking areas, garbage cans, and outdoor restrooms, since odors will be more attractive (especially from a distance) than the light.

Trapping Flies Outdoors

To capture flies outside, use traps with a screen cone suspended above the bait. These cone-type traps take advantage of the fly’s habit of flying or walking toward light. Cone traps can be easily made from wood and aluminum or plastic screening; use the dimensions shown in Figure 3. Flies are attracted to the bait in the pan under the trap. Once the flies are under the trap, the brightest spot they see is the hole in the cone above them. They walk up through the hole and are trapped in the outer screen cage. Since flies are attracted to the light and it is always lighter above them, they can not find their way back out through the hole in the cone.

FIGURE 3.

Cone Trap Diagram

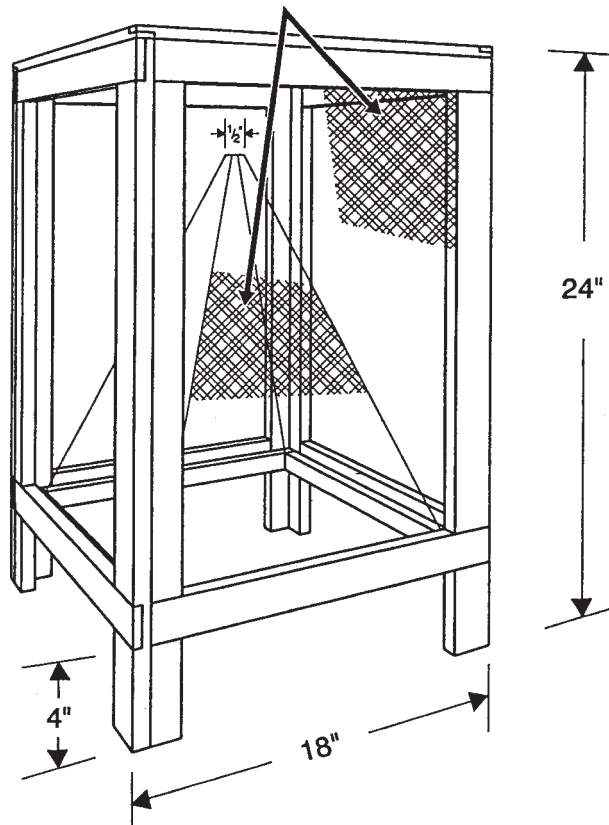

A bait pan is placed beneath the cone. Make sure the top edge of the bait pan is *above* the bottom edge of the trap. The top also is made of screening, and should be hinged (to empty the trap) and closed with a hook and eye. Weather-stripping or a strip of foam or cloth glued to all four sides of the underside of the lid will prevent flies from squeezing out.

The following are key points to remember when trapping flies outdoors.

— Trap placement is important.

- If an area has a small or moderate fly problem, traps placed close to buildings can attract flies from all over the neighborhood and make the problem worse. It is better to set the traps close to fly breeding sites, with any prevailing breeze blowing from the trap toward the breeding area.
- Do not set traps near doorways or entrances to buildings.
- Place traps away from outdoor areas that are used for eating or recreation.
- Generally, traps are most effective when placed on the ground, but they can be hung over the openings of dumpsters and from buildings or fences as well. Traps hung in these areas must not interfere with the

opening and closing of the dumpster, and should be placed in areas where people will not tamper with them and will not be offended by the bait odors.

- Place traps in sunlight. Flies are more active in sunlight, both outside and inside the trap.
- Empty the trap when dead flies cover about one quarter of the cone.
 - Do not release live flies that are in the trap. Kill them by enclosing the trap in a plastic bag and placing it in the sun. After the flies are dead, the contents of the trap should be poured into the plastic bag, sealed, and discarded in a dumpster or garbage can.
- Do not clean the trap between uses.
 - The smell of the millions of fly specks deposited on the screen is very attractive to flies.

Fly Bait Recipes

Bait is important to the performance of the trap. Here are some recipes and tips on using them.

BELTSVILLE BAIT

(from Pickens, et al., 1994)

This makes a dry bait that can be easily stored for a considerable time. It must be mixed with water before using.

Ingredients

- 1 pound granulated sugar
- 1 pound baking powder (double-acting type)
- 2 ounces dry active yeast (baking yeast)
- 6 ounces air-dried blood or freeze-dried fish meal
- ¼ cup honey
- 2 tablespoons* water

*Quantity of water needed may vary with the humidity of air when mixing. Use only sufficient water to bind dry ingredients together when they are compressed.

Procedure

Mix ingredients thoroughly. Press mixture into a plastic ice-cube tray to form cubes. Invert the tray to dump the cubes, and let them dry to form hard blocks. To use the bait, add 2 cubes of bait to 2 quarts of water. Place bait in a wide-mouth pan beneath a cone-type trap. Flies are attracted to this bait from only a short distance, so traps should be placed within 6 feet of areas where flies are active. Bait pans should be cleaned and baited every 1 to 2 weeks and should be kept filled with water.

LIQUID YEAST BAIT

(from Satrom and Stephens, 1979)

This recipe makes 7–9 portions of liquid bait for use with a cone trap. It can be stored 20–30 days once it is ready for use.

Ingredients

2 quarts tepid (not hot) water (95°–105° F)

1 cup and 3 ounces active dry yeast (baking yeast)

2 tablespoons ammonium carbonate (optional*)

*Ammonium carbonate is available from chemical supply houses and will improve the odor of the bait.

Mixing the bait

Use a plastic (not glass) narrow-necked gallon jug with a screw cap for mixing, ripening, and storing bait. Bleach or milk jugs work well. Wide-mouth containers will not produce effective bait.

Mix all the above ingredients in the jug. Important: With cap lightly sealed, allow mixture to begin to ripen (see ripening instructions below). It will foam up at first. After it subsides (1–2 days), tighten the lid and continue ripening till very smelly (2–9 additional days). Gases must escape while bait is foaming up (loose cap), but bait must finish ripening without air (tight cap) to attract flies.

Ripening the bait

Allow bait to ripen 4–10 days in a place where temperatures remain above 60°F during the night and day. Bait is ripe when it is very smelly, with a musky, penetrating odor. Warm daytime temperatures will make up for slightly cooler (less than 60°F) nights, but in general, the warmer the average temperature, the faster the bait will ripen. Because of its heavy odor, the bait should be ripened in a well-ventilated area where it will not offend people. Do not ripen or store the bait in direct sunlight. Extreme temperatures can build within the jug, kill the yeast, and cause gases to expand enough to pop off the lid or break the jug.

Storing the bait

To maintain potency, store bait with the cap kept tight. Open the jug only when necessary to refill the bait pan. Do not store in direct sunlight.

NOTE: Ripened bait should be treated as a decaying food material. It can cause gastrointestinal disturbances if ingested.

Using the bait

Stir or shake the bait supply each time before adding to the bait pan. Pour about 1 cup (8 ounces) of bait in a wide pan on a level surface under the trap. Be sure the edge of the pan is higher than the bottom edge of the trap frame.

The bait is effective in the pan for at least 3 to 5 days. It attracts more flies on the first day, and then gradually declines thereafter. Don't let the bait dry out.

- Liquid bait, either the *Yeast Bait* or the *Beltsville Bait*, is a superior attractant that will not breed flies unless it is allowed to dry to a sludge. If either of these baits contaminates clothing and hands, use baking soda and water to remove the odors.
- *Yeast Bait* has a foul odor that is particularly attractive to female flies because it smells like a good place to lay eggs. This bait will lure flies even from the most attractive breeding sites.
- *Beltsville Bait* will attract male flies as well as females because it contains sugar. This sweet bait can be used in

cool weather when the main aim of trapping is to reduce the total number of flies rather than to suppress breeding.

- Baits such as decaying meat or fish scraps will attract mainly blow flies and flesh flies. These baits should always be put inside a rolled down plastic bag and then placed in the bait pan. Periodically check the bait so that it does not become a breeding site for flies. The larvae feeding on the bait can crawl out of the plastic bag and away from the trap to pupate. If larvae are found in the bait, the plastic bag should be sealed, thrown away, and replaced with a new bag and bait.

- Sex pheromone baits for flies do not last long and do not attract flies from a distance. They are likely to be more expensive and less effective than food baits that can be made with common materials and attract both sexes.
- Poisons are not needed in the bait. Flies are more attracted to the live flies in the trap than they are to dead ones. However, if fruit flies begin breeding in the trap, a granular bait toxicant should be added.
- The top edge of the bait pan must be at least $\frac{1}{2}$ inch above the bottom edge of the trap. If flies can sit on the top edge of the bait pan and look out under the trap, trap catches will be poor.

Prevent excessive amounts of water from getting into the trap. If dead flies in the trap get wet and begin to rot, they may attract blow flies that will lay their eggs on the outside of the screen.

When the tiny blow fly larvae hatch, they crawl through the screen to feast on the rotting mass of flies. This turns the trap into a messy breeding site for flies.

- Do not place traps where sprinklers will get them wet.
- In areas where there are frequent rainstorms, it may be necessary to fit the trap with a clear Plexiglas top.

Chemical Controls

Except for odor-eliminating chemicals (such as borax) and baits, pesticides are not recommended for fly management. However, where children do not have access to dumpsters, baits inside and residuals on the outsides of dumpsters work well.

Borates

Low concentrations of borax in water can be used to eliminate fly odors. This solution is particularly effective for removing fly specks from walls and eaves, and for rinsing out garbage cans and dumpsters. These solutions should not be used near ponds, streams, lakes, or other bodies of water, and should not be poured onto plants.

Fruit Flies, Cluster Flies, Phorid Flies, and Moth Flies

IDENTIFICATION AND BIOLOGY

Fruit Flies

Fruit flies are small flies commonly seen flying around ripe fruit, especially bananas. They are about $\frac{1}{8}$ inch long. They lay their eggs near the surface of fermenting fruits and vegetables and other moist organic materials (including damp mops and cleaning rags, as well as residues in bottles, cans, garbage disposals, and drains). Their life cycle, from egg through maggot and pupa to adult, takes little more than a week, and the number of flies that can be produced by a single piece of fruit is enormous. These flies are most often a problem in late summer and early fall, so careful storage of fruit and vegetables is necessary at these times of the year.

Cluster Flies

Cluster flies are larger and darker than house flies and have a distinctive yellowish color caused by the crinkled yellow hairs on their bodies. In the summer, cluster flies lay their eggs in soil, where the maggots parasitize earthworms. Soil containing many earthworms is a common source of these flies. In the fall, the adults can be seen clustering on the south and west sides of buildings. As the weather gets cooler, these flies begin looking for sheltered places to spend the winter and often enter buildings.

Phorid Flies (Humpbacked Flies)

The most common phorid fly, *Megaselia scalaris*, is small ($\frac{1}{16}$ to $\frac{1}{8}$ inch long) with a yellowish-brown body and light brown wings. The adults seem reluctant to fly, and they run around on walls, windows, and tables with a characteristic quick, jerky motion. The females are strongly attracted to odors and lay their eggs on or next to decaying material, both plant and animal. Food sources for the larvae are highly varied, from decomposing fruit, vegetables, and meat to open wounds in animals and people to human and animal feces. The life cycle from egg to adult takes from 14 to 37 days.

Moth Flies (Drain Flies)

Moth flies (*Psychoda* spp.) are about $\frac{1}{16}$ to $\frac{1}{4}$ inch long, fuzzy, dark or grayish insects. Their body and wings are densely covered with hairs. Wings, appearing too large for the body, are held roof-like over the body when at rest, giving a mothlike appearance. During the day, adults often rest in shaded areas or on walls near plumbing fixtures and on the sides of showers and sinks. During the evening, these flies can be seen walking about drains and sinks.

They may breed in large numbers at sewage filter plants and then be carried by prevailing winds to nearby buildings up to a mile away. Adults are small enough to pass through ordinary window screening.

MANAGEMENT OPTIONS

Fruit Flies

Fruit flies are most active from early summer through early fall. Problems with these flies can be avoided by ripening fruit in paper bags. Seal the bags by folding the top over several times and closing them with paper clips or clothespins. Once fruit is ripe, store it in the refrigerator. Careful storage of fruit during the rest of the school year may not be necessary.

If an infestation is discovered, look for and remove the material that is breeding the flies. Begin by searching for the obvious sources, such as ripe fruit and vegetables, then look at water from refrigerators, humidifiers, or sink drains that may be fermenting; spoiled animal food; or even damp, sour mops or rags. Areas outside the building near windows and doors should be checked for rotting vegetable matter. All breeding sources should be removed and disposed of in a sealed plastic bag. Make sure that screens and windows near food preparation areas are in good repair.

Fruit Fly Trap

To make a simple trap for fruit flies, combine 1 cup of vinegar, 2 cups of water, and 1 tablespoon of honey in a 2-liter soda bottle. Replace the cap, shake the mixture well, and punch holes in the side of the bottle above the liquid so the flies can get in. Using string, hang the bottle about 5 feet above the ground. Periodically, the dead flies should be strained out and the liquid reused.

Cluster Flies

Cluster flies are not as strong fliers as house flies and can easily be killed with a fly swatter or removed with a vacuum. Cluster flies also can be allowed to exit by opening the window. They can find their way into buildings through unscreened doors and windows, openings under siding and around roofs, unscreened ventilating spaces, cracks around windows, and holes where wires penetrate the walls of the building. During warm winter periods, cluster flies hidden in buildings become active and are attracted to windows.

Phorid Flies

Phorid flies breed in diverse sources of organic matter, so it may take considerable sleuthing to find their breeding sites. Once a site is found, it must be thoroughly scraped, cleaned, and dried. Large infestations of these flies are often the result of broken drains or garbage disposals that allow organic matter to accumulate in out-of-the-way places such as wall voids, under floors, in basements, or in the soil of crawl spaces.

Moth Flies

Moth flies do not bite humans, but may become a nuisance by their presence in large populations. Concentrate on eliminating larval breeding sites from drains in floors, sinks, wash basins, showers, and similar places. To determine if the flies are coming from a drain, place a glue board, sticky side down on a collar made of cardboard, over the drain during a down time. Leave in place overnight or for a few days to monitor for the flies.

Often the most effective method is to clean the drain pipes and traps regularly to eliminate the gelatinous, rotting organic matter, thus eliminating the larval food source. Infestations developing in drains often can be eliminated by flushing these areas with sink cleaning materials followed by very hot water. Clean dirty garbage containers, standing water in air conditioners, or other sources of stagnant water in the area.

Mosquitoes

INTRODUCTION

Since the introduction of West Nile virus into the United States, the public has a heightened awareness of the importance of mosquito control. Persons most at risk from West Nile virus are the elderly and those with weakened immune systems. Not all mosquitoes carry the pathogen, nor do all people respond the same to transmission of the pathogen.

Mosquitoes also can transmit pathogens besides West Nile virus; for example, some are vectors of Eastern Equine encephalitis virus, Western Equine and St. Louis Equine encephalitis viruses, dog heartworm, and other pathogens. The three most important mosquito groups (see Figure 4) are the *Anopheles* (carrier of malaria), *Culex* (carrier of viral encephalitis), and *Aedes* (carriers of yellow fever, dengue, and encephalitis). An effective mosquito control program is essential to prevent these potential problems.

MOSQUITO LIFE CYCLE

Mosquitoes breed in standing water. This includes swamps, storm retention basins, culverts, ponds, lakes, and natural or artificial containers such as tree holes, hollow stumps, pots, cans, tires, animal tracks, and plugged rain gutters. Some mosquitoes are capable of flying many miles, so control may need to be area-wide. All mosquitoes are less than 1/2-inch long as adults.

During their life, mosquitoes pass through four distinct stages: egg, larva, pupa, and adult.

Eggs are deposited either individually or in groups called rafts on the surface of water or on soil where flooding will produce puddles or pools. Most eggs hatch within 48 hours.

Larvae are called wrigglers because of their wriggling motion in the water. The wrigglers feed on organic debris and microorganisms and breathe at the surface of the water through tubes. After molting several times as they grow, they form pupae.

Pupae are sometimes called tumblers because of their defensive motion to escape predators. They are shaped somewhat like a comma.

Adults emerge from the tumblers, and as long as water is available in their habitats, the population gradually increases through the summer. The entire life cycle varies from 4 to 30 days, depending on the species.

Figure 4 shows the stages as well as characteristics that can help distinguish the three important mosquito groups.

Adult females must have a blood meal before they can lay eggs. They have elongated piercing-sucking mouthparts used to penetrate the skin and ingest blood. The bite of the mosquito, in itself, causes little harm, although itching and swelling in response to the mosquito saliva, which contains a substance that prevents blood clotting, may develop. The real harm can result from the mosquito potentially being a vector for several disease pathogens.

MANAGING MOSQUITOES

Eliminate Mosquito Breeding Sites

By eliminating mosquito breeding sites on school property, the number of mosquitoes can be reduced in the area.

- Dispose of anything outside that can hold water, such as tin cans, containers, pots, and particularly used tires, which have become the most important mosquito breeding sites in the country.
- Drill holes in the bottoms of recycling containers left outdoors.
- Turn over wheelbarrows and other water-holding tools when not in use.
- Do not allow water to become stagnant in birdbaths, ornamental pools or other outside areas.
- Empty accumulated water from any trailers.
- Keep dumpsters and trash receptacles covered to prevent water accumulation.
- Alter the landscaping to eliminate standing water. Keep in mind that during warm weather, mosquitoes can breed in any puddle of water that lasts more than four days.

Eliminate Adult Resting Sites

Cut back or remove dense brush and other vegetation from around buildings. Keep grassy areas mowed. Promote natural breezes to discourage mosquito occurrence.

Biological Control

Biocontrol is the use of biological organisms to control pests. Larvivorous fish are the most extensively used biocontrol agent for mosquito control. Predaceous fish, such as bluegills (*Centrarchidae*) and killifish (*Cyprinodontidae*) can be placed in permanent or semipermanent water bodies for larval control. Other biocontrol agents have been tested, but so far have generally not been operationally feasible.

Some of this material has been adapted from:

Pitts, C. W., G. L. Holbrook, S. I. Gripp and W. K. Hock. *Mosquito Biology and Control*. The Pennsylvania State University.

www.pested.psu.edu/spWNmosqbio.pdf

Higgins, W. *Policy and Procedures For Mosquito Control*. Western® Pest Service, Voorhees, N.J.

Proceedings of the Seventy-Sixth Annual Meeting of the New Jersey Mosquito Control Association, Inc., 1989. pp. 45–50. www.rci.rutgers.edu/~insects/larvsurv.htm

FIGURE 4. Characteristics of three groups of mosquitoes

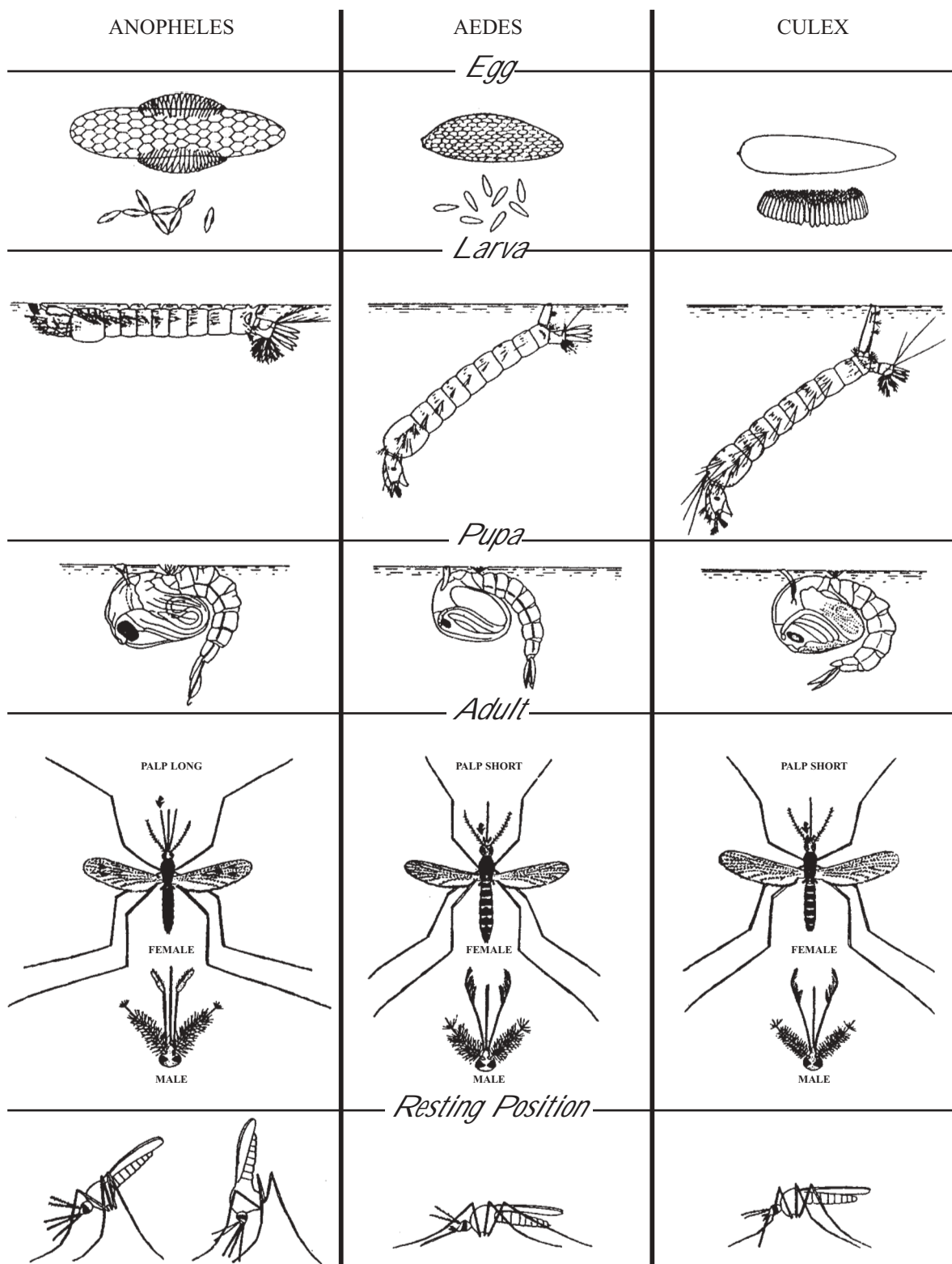

Avoidance

- Reduce outdoor exposure, especially at dawn, dusk, and in the early evening during peak periods of mosquito activity (April to October).
- Avoid areas where mosquitoes tend to concentrate—in tall grass, margins of wooded areas, or in heavily wooded areas in dense vegetation.
- Avoid wearing dark colors. Mosquitoes and other biting flies are attracted to dark greens, browns, and black. They are less attracted to light-colored clothing, especially whites and yellows.
- Make sure window and door screens are in good repair.

Repellents

Apply insect repellent sparingly to exposed skin. An effective repellent will contain 20 to 30 percent DEET (*N,N*-diethyl-3-methyl-*m*-toluamide). Avoid products containing more than 30 percent DEET, since in high concentrations (more than 30 percent) DEET may cause side effects, particularly in children. Spray clothing with the repellent also, as mosquitoes may bite through thin clothing. (From the Pennsylvania Department of Health, www.WestNile.state.pa.us/citizenfactsheet.htm).

Chemical Control

Pennsylvania law allows pesticide applications in schools only by certified applicators, registered technicians, or by non-certified applicators or non-registered technicians under the direct supervision of a certified applicator. Notification must be given to all staff and parents or guardians of students who request it 72 hours prior to pesticide use. Warning signs must also be posted in the vicinity 72 hours prior to and for 48 hours after the application. The law also mandates a 7-hour reentry period for common access areas whenever pesticides are applied.

For most pesticides placed in water, a permit must also be obtained from the Pennsylvania Fish and Boat Commission. However the commission will allow persons to treat impounded waters with a mosquito larvicide that contains *Bacillus thuringiensis israelensis* (B.t.i.) or *Bacillus sphaericus* for waters where:

1. The water body is 1 surface acre or less.
2. The water body being treated does not have a discharge over the effective treatment period.
3. The water contains no fish (bait fish or game fish).

In general, mosquito larvae control is more effective than attempting to spray for adults. If special conditions are present, contact the Pennsylvania Fish and Boat Commission at 814-359-5147. The forms for other

aquatic applications are available from regional offices of the commission, the Pennsylvania Department of Environmental Protection, the Pennsylvania Department of Agriculture, Penn State Cooperative Extension county offices, district forester offices, Pennsylvania Soil and Water Conservation District offices, or the Soil Conservation Service county offices.

Larvicides

Chemicals used to kill immature mosquitoes are typically more effective and target-specific than adulticide, yet less permanent than habitat modification. Several materials in various formulations are labeled for mosquito larviciding, including some biorational pesticides, diptera-specific bacteria, insect growth regulators (IGR), and chitin synthesis inhibitors. Also labeled for mosquito control are conventional insecticides, several nonpetroleum oils, and monomolecular film.

The timing of larvicide application is dependent on the nature of the control agent. Conventional insecticides kill larvae at all stages and can be applied when convenient. Bacterial toxins must be consumed by the larvae and are usually applied well before the fourth molt to ensure consumption. IGR's must be applied later in the larvae's development to upset the molting process. Chitin synthesis inhibitors are effective throughout the entire larval life. Monomolecular films prevent the insect from remaining at the surface of the water by reducing surface tension, causing the larvae and pupae to die. Nonpetroleum oils kill larvae and pupae by suffocation. Give full attention to the label directions.

Adulticides

The ground or aerial application of chemicals to kill adult mosquitoes is usually the least efficient mosquito-control technique and is considered the last resort when other methods have failed. Adulticides are often applied as ultra-low-volume sprays in which small amounts of insecticide are dispersed either by truck-mounted equipment or from fixed-wing or rotary aircraft. The tiny droplets must contact the mosquitoes to be effective.

Questionable Control Methods

Many devices are being sold to control mosquitoes, but not all are effective. For example, outdoor insect light traps (bug zappers), Citrosa plants, and others are generally ineffective in controlling mosquitoes. Even bats and purple martins have been shown to be no more effective than bug zappers in mosquito control as both are opportunistic feeders and they will feed on any insects available rather than specialize on mosquitoes.

MONITORING FOR MOSQUITOES

The following techniques will cover most of the basic aspects of mosquito monitoring and control. Various combinations of these methods can be utilized to manage mosquitoes.

A sketch or plot plan of the school grounds is helpful in recording locations where management may be needed.

Larval Surveillance Methods and Equipment

Larval surveillance is an important aspect of an effective mosquito monitoring program. It can be used to determine the location, species, and population densities of pest and vector mosquitoes. It is vital for predicting adult emergence and establishing optimal times for application of larval control measures. It is used to forecast the need for adult mosquito control and to assess the effectiveness of both chemical and biological control measures.

Basic tools required for larval surveillance are: a standard, enameled, or plastic dipper about 4 inches in diameter (1 pint or 350 ml capacity), used for taking larval samples (the handle of the dipper may be lengthened by inserting a suitable piece of wood dowel or PVC pipe); a small pipette or eyedropper; a pair of boots; vials, 6 oz plastic bags or some other container for collecting larvae; labels for the collections; and a pencil.

Mosquito larvae are found in a great variety of habitats. A number of different sampling techniques are needed to determine the presence or absence of immature mosquitoes and to estimate their numbers.

When searching for mosquito larvae, proceed slowly and carefully. Approach the area to be inspected with caution, as heavy footfalls will create vibrations that disturb larvae and cause them to dive to the bottom. Likewise, avoid disturbance of the water, as this will have the same result. Approach the area to be sampled with the sun in one's face; this prevents shadows, which also disturb larvae and cause them to dive. If it is windy, dipping should be done on the windward side of the habitat where larvae and pupae will be most heavily concentrated.

Mosquito larvae are usually found where surface vegetation or debris are present. In larger pools and ponds, they will usually be confined to the margins and will not be found in open, deep water. Dipping should be done around floating debris, aquatic and emergent vegetation, logs and tree stumps in the water, and grasses around the margins. Look for the presence of larvae and pupae before beginning to dip.

The kind of mosquito larvae you are looking for, as well as the type of habitat you are working in, will determine the dipping technique used. Choose the most

appropriate technique to obtain the most reliable results. The following seven techniques have been developed for sampling mosquito larvae and pupae with the standard pint dipper:

1. **The Shallow Skim**—*Anopheles* larvae are normally found at the surface of the water among aquatic vegetation or floating debris. They can be collected with a shallow, skimming stroke along the surface, with one side of the dipper pressed just below the surface. End the stroke just before the dipper is filled to prevent overflowing.
2. **Partial submersion**—Around emergent vegetation, logs and tree stumps, larvae may be drawn into the dipper by submerging one edge so that the water flows rapidly into the dipper. In this method, the dipper is stationary within the water.
3. **Complete submersion**—Certain Culicine larvae (such as species of *Aedes* and *Psorophora*) are very active and usually dive below the surface when disturbed. In this case, a quick plunge of the dipper below the surface of the water is required, bringing the dipper back up through the submerged larvae. Bring the dipper back up carefully, to avoid losing the larvae with overflow current.
4. **Dipper as a background**—This is an especially useful technique in woodland pools, for early season species. Submerge the dipper completely within the woodland pool, going down into the bottom litter if necessary. Use the white dipper as a background against which larvae and pupae can be spotted. Come up underneath the larvae with the dipper. Once again, bring the dipper up carefully to avoid losing its contents.
5. **“Flow-in” method**—This method is useful in situations where the water is shallow, with mud, leaf litter, or other debris on the substrate. Specimens can be collected by pushing the dipper down into the material on the bottom and letting the shallow surface water and mosquito larvae flow directly into the dipper.
6. **Scraping**—This method is used in permanent or semi-permanent habitats containing clumps of vegetation, such as tussocks. Dip from the water in, towards the tussock, and end by using the dipper to scrape up against the base of the vegetation to dislodge any larvae present.
7. **Simple scoop**—This technique seems to be the one most commonly used by field personnel for larval surveillance and is frequently referred to as “the standard dipping procedure.” The technique involves simply scooping a dipperful of water out of a habitat. It is useful in a wide variety of habitats, especially for collecting *Culex*.

The basic information collected with each sample should be: the date, location or site, type of habitat, climatic conditions, degree of cloud cover present, the larval or pupal density, stages present, and species (determined in the lab through identification).

An average of 5 to 7 larvae per dip may indicate a need for using a larvicide in the area.

An approximate time line to follow in a monitoring program is:

1. Mid-March: First sample taken. Although this is still in the cold part of the spring, and dip samples will most likely be negative, monitor anyway. This will allow the pinpointing of potential areas of activity later.
2. April through June: Monitor every two weeks.
3. July through September: Monitor weekly, as this is the peak part of the season.
4. October finishes mosquito season. A sampling at this time can help assess the effectiveness of the control program.

Samples and collection data can be submitted to the state or county health department. Larval and adult samples may be collected and preserved in 70 or 90 percent ethyl alcohol for identification purposes.